

KANCA

CONCRETE IRON BAR BENDERS

Concrete Iron Bar Benders

- 1 Ability to bend 3 bars at one time
- 2 Rollers from quality steel at (30-35 HRC) hardness
- 3 Lubrication Hole*
- 4 Lever from quality steel
- 5 Fixing from 6 locations possible

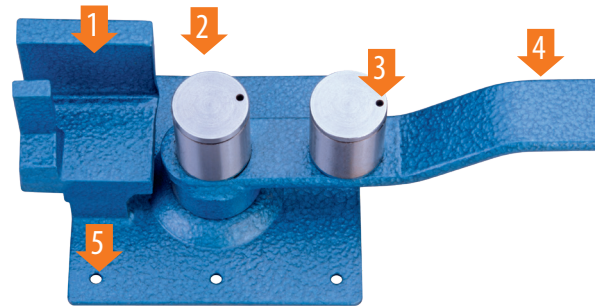

* Bevor benutzen des Biegers ölen
Lubricate the rollers, each time before working, with fine oil.

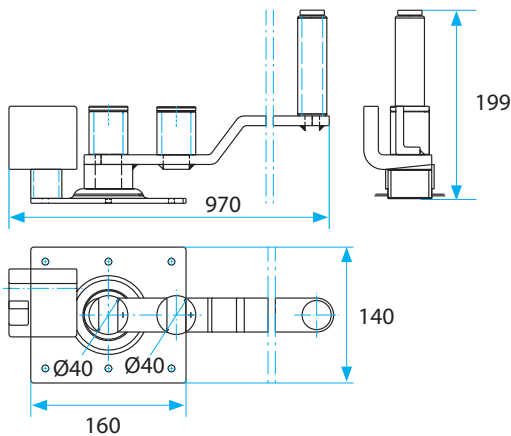

Code	Instructions (Ø mm)	(kg)	
60505010812	8 - 10 - 12 mm	7	1
60505010814	14 - 16 mm	9.9	1

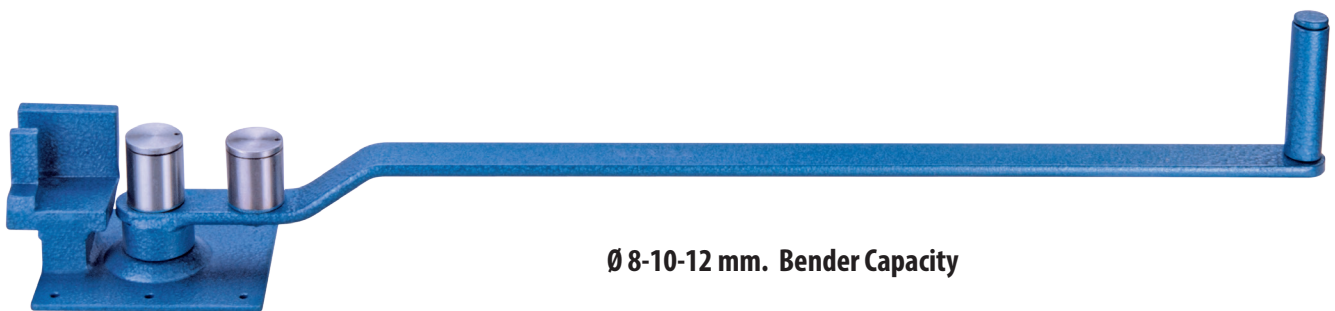

Ø 8-10-12 mm. Bender Capacity

