

DÖVME ÇELİK

KANCA

STANDART İŞKENCE

Ağır metal işlerinizde mükemmel yardımcı.

Dövme İşkence

- Dövme Çeneler
- Ovalama tekniğiyle üretilen sıkma vidası
- Sıcak çekme tekniğiyle üretilen bükülmez lama
- Lama kenarlarında kaydırmaz tırtıklar
- Ergonomik metal sıkma sapı
- Çelikten üretilen hareketli sıkma marpucu

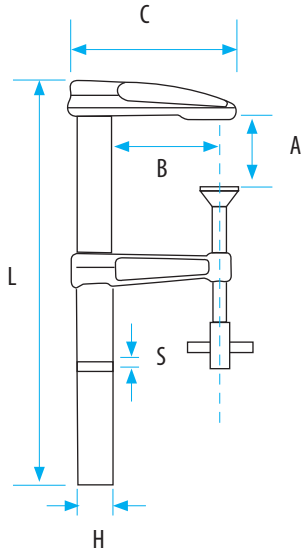
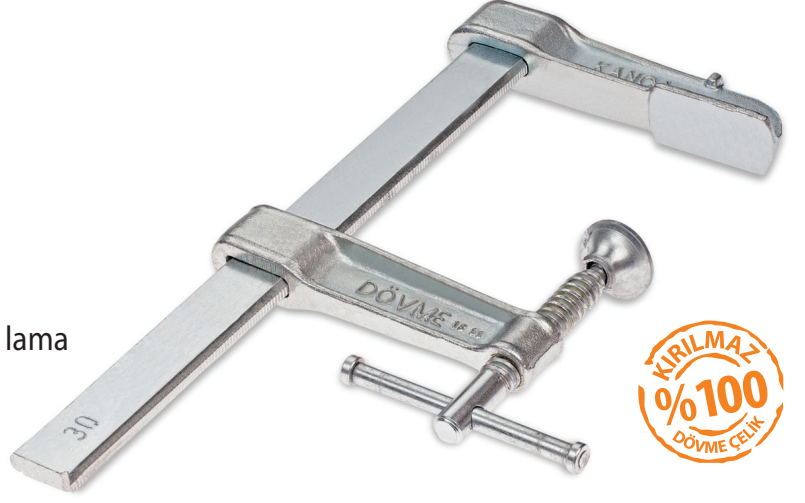

Ürün Kodu	A (mm)	B (mm)	HxS (mm)	L (mm)	C (mm)	gr	
60108010020	200	120	35x11	300	185	2550	6
60108010025	250	120	35x11	350	185	2650	6
60108010030	300	120	35x11	400	185	2800	6
60108010040	400	120	35x11	500	185	3100	6
60108010050	500	120	35x11	600	185	3300	6
60108010060	600	120	35x11	700	185	3600	6
60108010070	700	120	35x11	800	185	3900	6
60108010080	800	120	35x11	900	185	4200	6
60108010090	900	120	35x11	1000	185	4450	6
60108010100	1000	120	35x11	1100	185	4800	6
60108010110	1100	120	35x11	1200	185	5000	6
60108010120	1200	120	35x11	1300	185	5300	6
60108010130	1300	120	35x11	1400	185	5600	6
60108010140	1400	120	35x11	1500	185	5950	6
60108010150	1500	120	35x11	1600	185	6200	6
60108010160	1600	120	35x11	1700	185	6600	6
60108010180	1800	120	35x11	1900	185	7000	6
60108010200	2000	120	35x11	2100	185	7600	6
60108010250	2500	120	35x11	2600	185	9100	6
60108010300	3000	120	35x11	3100	185	10600	6

KANCA
DESIGN • FORGE • SAFETY